

R-SMART PLUS ENDO MOTOR USER MANUAL



Contents

1 Introduction	1
2 Notice	4
3 Installation	6
4 Operation	8
5 Trouble shooting	15
6 Cleaning and Sterilization	17
7 Storage, maintenance and transportation	18
8 Environmental protection	18
9 Warranty	18
10 Standard symbols	19
11 Statement	20

1 Introduction

1.1 Description of the device

Endo Motor is a supporting device of endodontic treatment, through enlarging root-canal in the process, helping dentists to finish the endodontic treatment.

Device Features:

a) With Multi-Frequency length measuring technology and the function of root-canal length measuring and enlargement.

b) Ultraprecise motor originating in German; Large colorful OLED screen, all angles visible.

c) Four operation models and six functions including Reciprocating motion, Automatic deceleration in apical zone, Automatic inversion and stopping in apical zone, Automatic start/stop of motor, Automatic inversion of torque, Both root-canal length measuring and enlargement.

Main accessories include: Contra-angle handpiece, File clip, Lip hook and Measuring file, which can be sterilized in high temperature and pressure to avoid cross infection.

1.2 Model, Dimensions and Weight of main unit

Model: R-Smart Plus, Dimensions: 135mm×100mm×115mm, Weight:347g

1.3 Structure

R-Smart Plus is composed of main unit, handpiece, contra-angle, measuring wire, file clip, measuring file, adapter and handpiece stand.

1.4 Intended use

R-Smart Plus is an electronic device used for enlarging root canal. This product must only be used in hospital environments, clinics or dental offices by qualified dental personnel.

1.5 Contraindications

The R-Smart Plus is not recommended for use:

a) In patients who have a pacemaker or other implanted electrical devices, or have

been cautioned by their physicians against the use of small electric appliances such as shavers, hair dryers, etc.

b) In patients allergic to metals.

c) In children.

1.6 Components

1.6.1 The structural figure of the device. (Fig. 1.1)

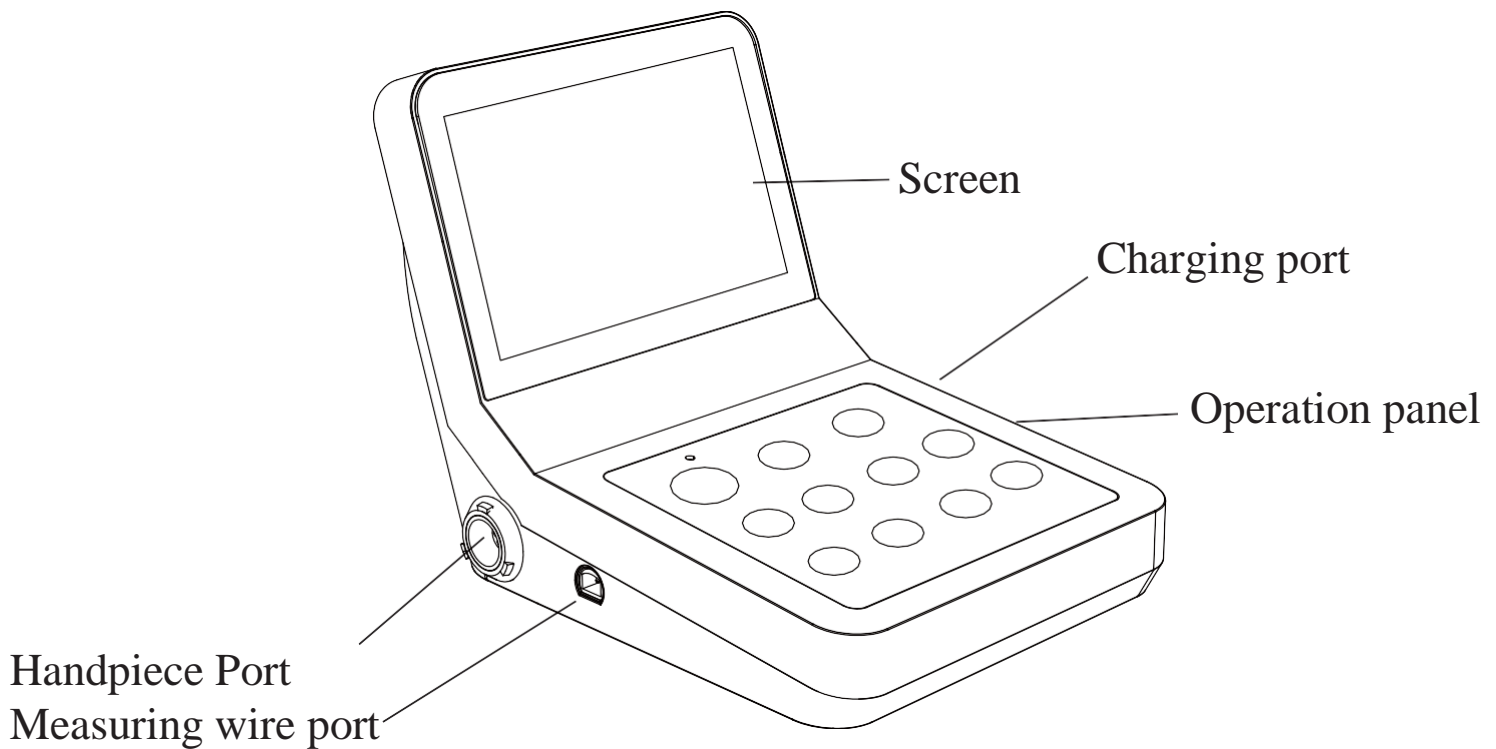
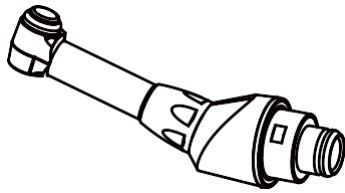
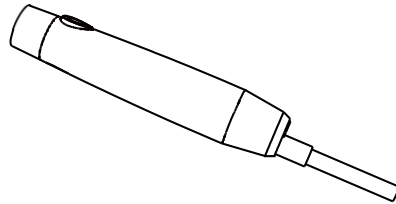

Fig. 1.1 Product appearance structure

1.6.2 The figures of the main accessories. (Fig. 1.2)



a Contra-angle



b Motor handpiece

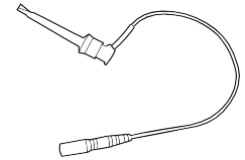

c File clip

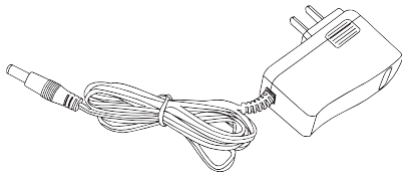

d Adapter

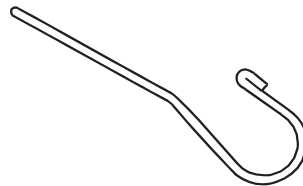

e Lip hook

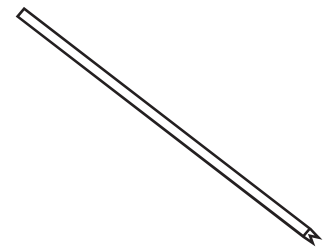

f Measuring file

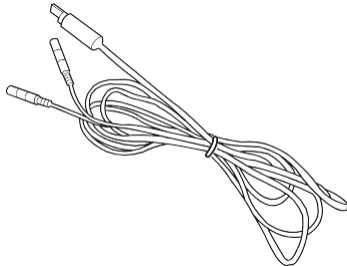

g Measuring wire

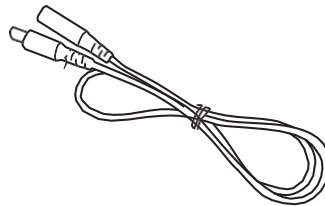

h Single-head measuring wire

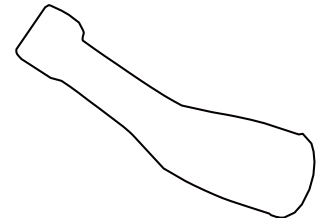

i Silicon rubber case

Fig. 1.2 The figure of the main accessories.

1.7 The classification of the device

1.7.1 Type of protection against electric shock: Class II internally powered equipment.

1.7.2 Degree of protection against electric shock: Type B applied part.

1.7.3 Degree of protection against water shock: Ordinary equipment (IPX0).

1.7.4 Device not suitable for use in the presence of flammable anesthetic mixtures with air, oxygen or nitrous oxide.

1.7.5 Operation mode: Continuous operation.

1.8 The main technical specifications

1.8.1 Battery: 7.2V/1400mAh

1.8.2 Adapter: ~100V-240V 0.8A 50Hz/60Hz

1.8.3 Revolving speed: 200~600 rpm

1.8.4 Torsion: 0.6~4.0 N•cm

1.8.5 Buzzer alert: The buzzer will alert when the file is less than 2mm closed to the apex.

1.8.6 Operation condition

a) Environment temperature: 0~40°C

b) Relative humidity: 10~85%RH.

c) Atmosphere pressure: 70kPa~106kPa

2 Notice

2.1 Please read the user manual carefully before the operation.

2.2 While being on operation, the scale indication on the R-SMART PLUS screen does not represent a distinct length or distance in mm or other linear units. It simply indicates the file progression towards the apex.

2.3 While being on operation, the following patient's related factors may prevent accurate readings: Blocked root canals, Cracked root canals, Perforated root canals, Root fracture or perforation, Metal crowns or bridges contact with the file or the lip file, The inner liquid link to the outer liquid of root canals, Very dry root canals, The file or the file clip contact with other metal or instruments.

2.4 Inaccurate or incorrect readings due to the environment are likely to occur in the following cases:

- a) Presence of portable or movable radio frequency transmitters in the surroundings.
 - b) Electromagnetic interference could cause improper operation of the device.
- 2.5** This device has electromagnetic interference which is similar to other device, the patient or doctor who with a pacemaker are forbidden to use this device.
- 2.6** While being on operation, the apical position is located to the place apex locator screen indicates “00”, as a safety precaution in order to avoid over-instrumentation, it is recommended to subtract 0.5 mm-1.0mm to determine the working length for shaping.
- 2.7** Please do not use the file which is broken, crooked and not meeting the ISO standard to avoid any kind of danger.
- 2.8** Please pay full attention to the device if there is loose, vibration, noise and heat, and pre-test before operation. If any abnormal phenomena, please stop using immediately and contact local agent or manufacture.
- 2.9** Do not collide, especially to avoid falling.
- 2.10** Please clean the collet of file and set aside because the inside parts might be damaged once polluted.
- 2.11** Please remember to turn off the device firstly if need to debus the contra-angle and files.
- 2.12** Please recharge the battery when the battery power is low and indicator flashes.
- 2.13** Only the original accessories to this device.

3 Installation

3.1 Connecting the Contra-angle and Handpiece (Fig. 3.1)

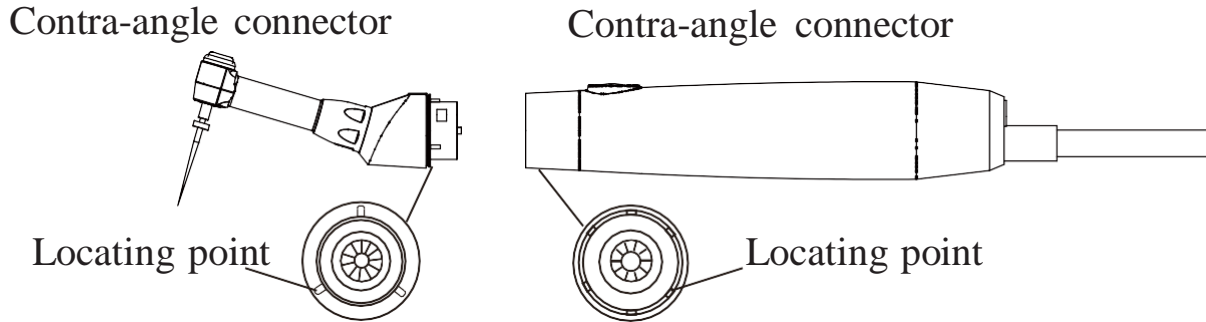

Fig. 3.1 Explanation of connecting the contra-angle and handpiece

- a) Before using this instrument, clean all the parts which may contact with patients.
- b) Only match the locating points of both contra-angle and handpiece, they can connect smoothly.

3.2 Connecting the Main unit and Components (Fig. 3.2)

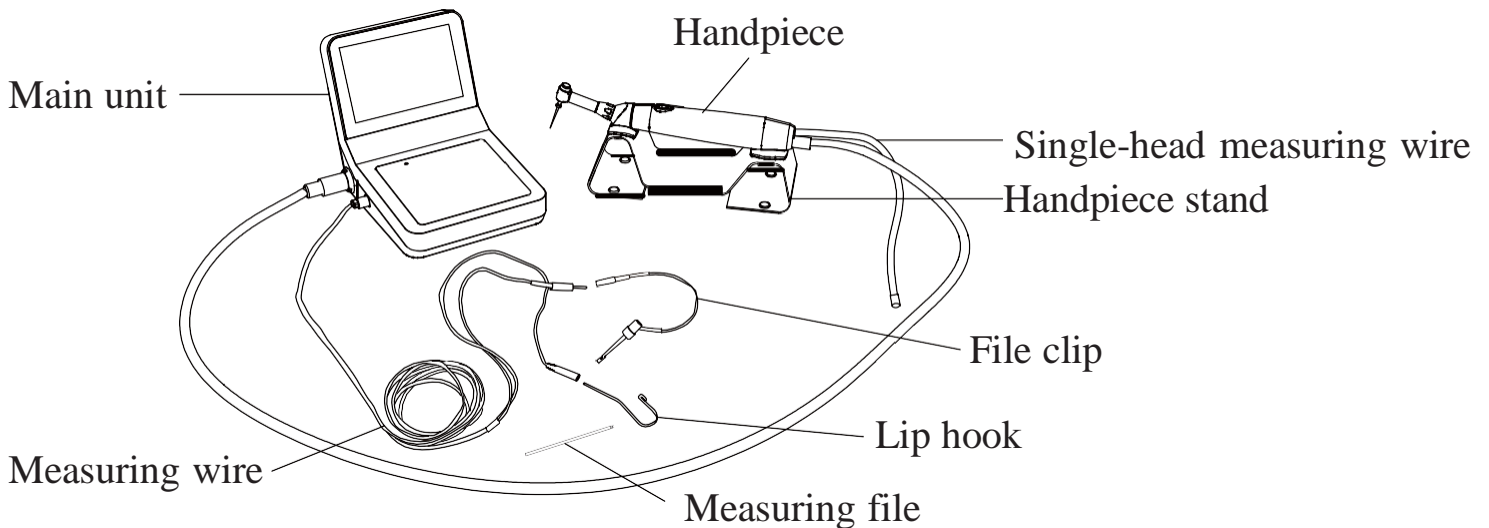

Fig. 3.2 Explanation of connecting the main unit and components

3.3 Charge the battery

When the power indicator flashes, please stop using the device and recharge the battery.

a) Connect the AC adapter with the right side socket of the device properly, and insert the AC adapter plug to the power socket.

b) The yellow indicator is lighted when the device is charging, it means charging has finished when the yellow indicator turns down. It may spend 4 hours for charging because of the high capacity battery.

Attention: Please don't use the device when it is charging.

3.4 Automatic shutdown

When not used for 5 minutes, R-Smart Plus will automatically shut down and all of the display and function are stopped.

3.5 Automatic calibration

Insert handpiece cord into main unit and connect contra-angle with handpiece, and when machine is off, press the POWER button as well as the SET button for 3 second, it will enter calibration mode, which will make motor low-speed to high-speed until stopping.

Attention: This function is only for replacing of contra-angle or handpiece and during this process, please do not touch the contra-angle or file to avoid calibration error. After calibration, the device will be normal use again after rebooting.

4 Operation

4.1 R-Smart Plus function definition (Fig. 4.1/4.2)

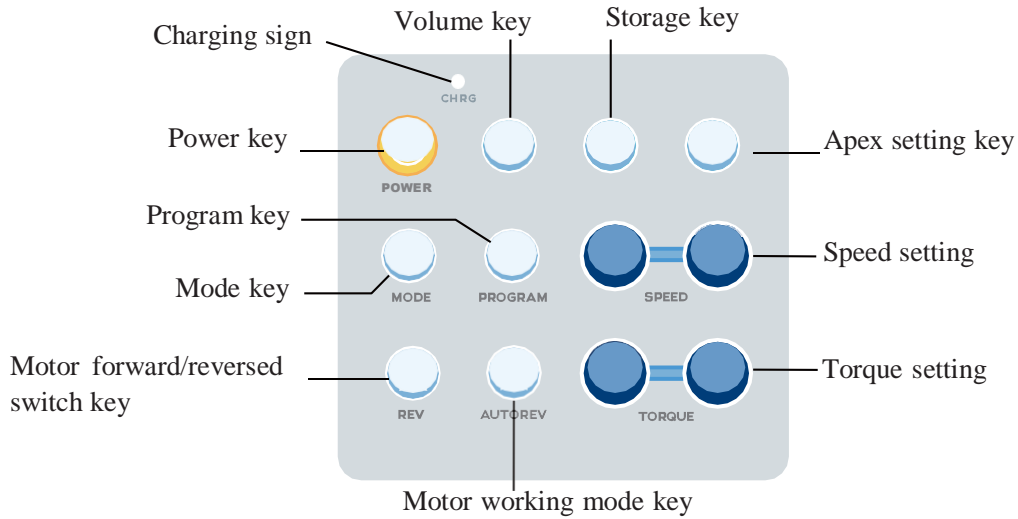

Fig. 4.1 Explanation of operation panel

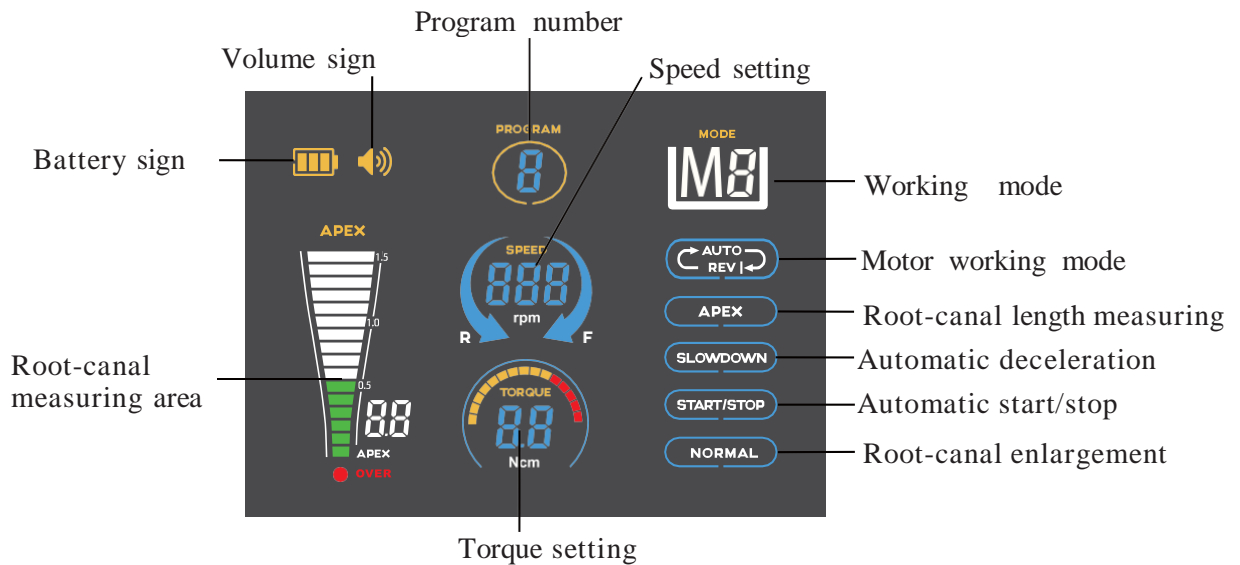

Fig. 4.2 Explanation of LCD screen

4.2 Specific Instructions

POWER: Switches the device on or off (LCD screen lights up or goes out)

VOLUME: Adjusts the sound volume or mute

STORAGE: Saves the current setting data of speed, torque, auto reverse and root tip limit value into program

APEX SETTING: Sets the root location (in M4 mode, file will be auto reverse when arrives the pre-set root location)

MODE: Switches the 4 operation modes

M1: Only root-canal length measuring

M2: Only root-canal enlargement

M3: Reciprocating rotary motion

M4: Both root-canal length measuring and enlargement

M5: Both reciprocating rotary motion and length measuring

MODE	NORMAL	APEX	SLOW DOWN	START/ STOP
M1	NO	YES	NO	NO
M2	YES	NO	NO	NO
M3	YES	NO	NO	NO
M4	YES	YES	YES	YES
M4	YES	YES	NO	YES

PROGRAM: Switches the programs and show the data from corresponding ones on screen.

SPEED SETTING: 200~600 rpm

TORQUE SETTING: 0.6Ncm-4.0Ncm

MOTOR WORKING MODE: Switches the 3 operation modes of file

**AUTO
REV**

File will stop when the stress is more than setting torque data.

**AUTO
REV**

When the stress is more than setting torque data, file will auto reverse. If remove the stress, file will stop.

**AUTO
REV**

When the stress is more than setting torque data, file will auto reverse. If remove the stress, file will forward roll again.

Manual forward or reversal switch: Change the rolling direction once press



Handpiece Bottom: Control the handpiece to work or stop with two modes:

- a) Short pressing for working, again for off.
- b) Continuous pressing for working, releasing for off.

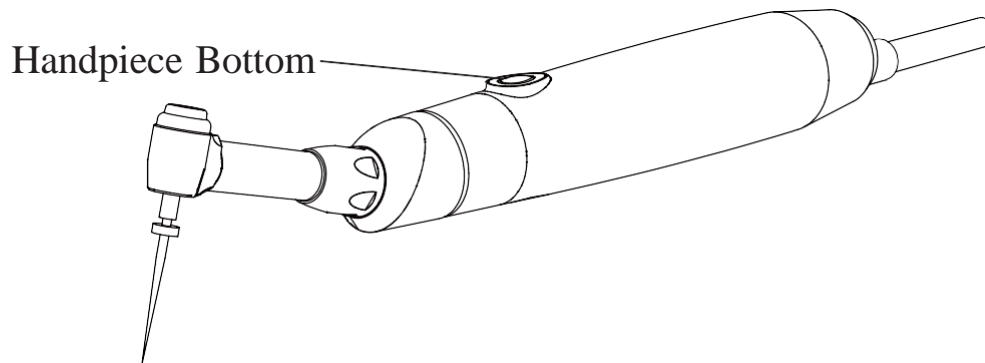

4.3 The installation and use of M1 mode

Insert the plug of the measuring wire into the left side socket of the unit. Insert the file clip and lip hook respectively into the two sockets of the measuring wire. (Fig.4.3)

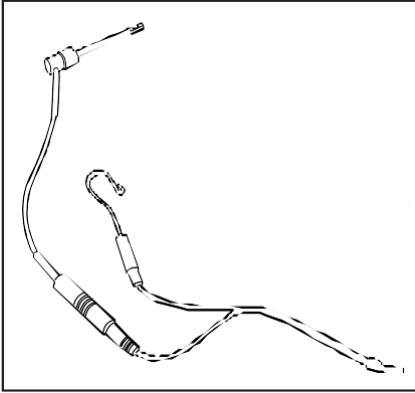

Fig.4.3

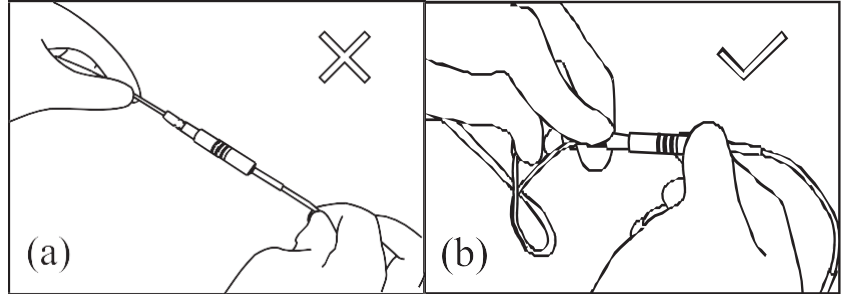
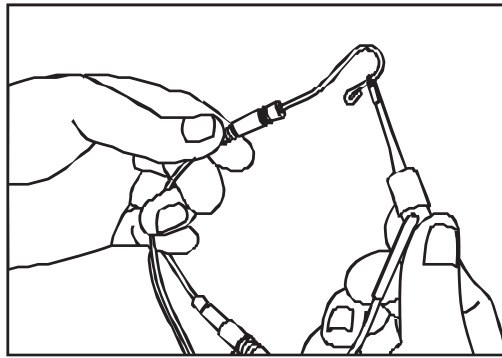

Fig.4.4

Attention: Do not draw the wire when inserting or pulling out measuring wire.
 (Fig. 4.4a incorrect operation. 4.4b correct operation.)

- a) Make sure the measuring wire is inserted correctly.
- b) Make sure the measuring wire is connected with file clip and lip hook.
- c) Make the lip hook touch the bent wire of the file clip (as showed in Fig. 4.5a), the screen will show the length of root canal, as showed in Fig. 4.5 (b), with beep sound.



a

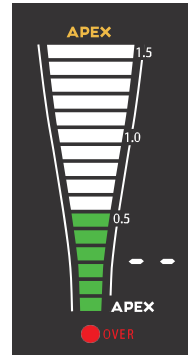

b

Fig.4.5

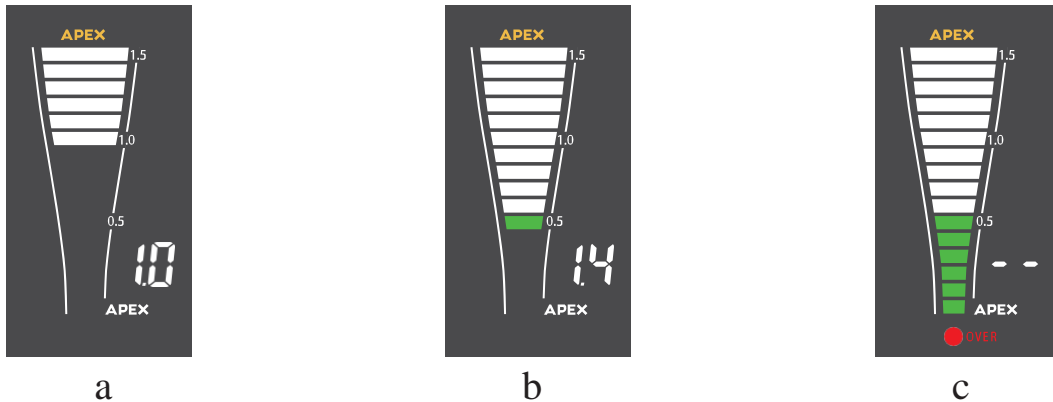

Fig.4.6 Explanation of the interfaces displayed

a) The white region of instruction bars on the screen is the front region of the apical foramen. (Fig. 4.6a)

b) The file position is near by the apical foramen when the green bars displayed. (Fig. 4.6b)

c) The file exceeds the apical foramen, the bars reach red zone and make a continuous beep sound. (Fig. 4.6c)

d) The number on the screen doesn't stand for the distance to apex, but only the trend moving toward or away the apex.

Operation

Insert the plug of measuring wire into the left side socket of main unit. Turn it on. The screen will display the measuring interface.

The instrument will automatically shut down after 5 minutes without operation or pressing SWITCH OFF button.

Press the volume button to control volume of beep sound.

Hang the lip hook on the lip, and make sure that it contacts the oral mucosa as a reference electrode. (Fig. 4.7)

Clip the metal part near the file shank vertically with the file clip, and then push the file towards to the apex slowly, the continuous alarm will sound when the distance is less than 2mm.

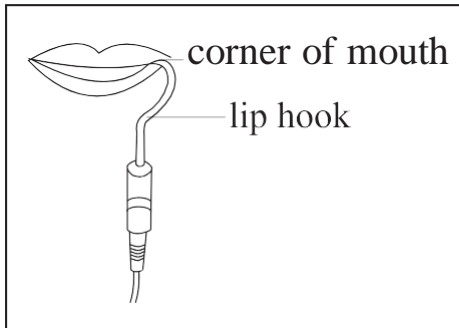

Picture 15

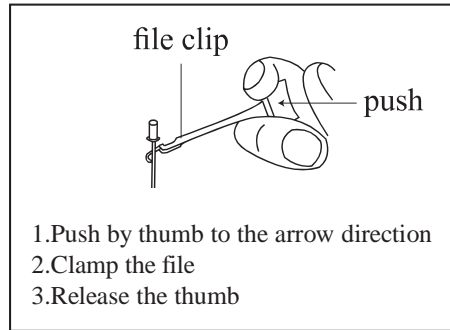

Picture 16

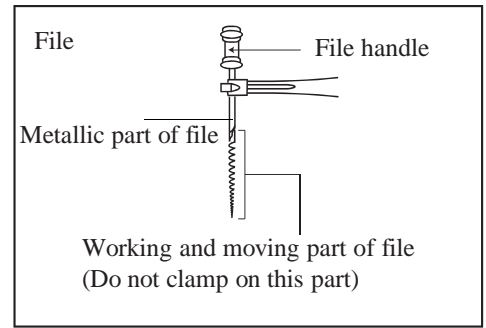

Picture 17

Fig. 4.7

When the file reaches the apical position, adjust the rubber piece of the file set to the reference point (incisal edge or fossa edge), then pull out the file, measure the length between the file tip and the rubber piece. And the length is the working length of the tooth. File clip can be replaced by touch probe if it is inconvenient to measure the back teeth. (Fig. 4.8)

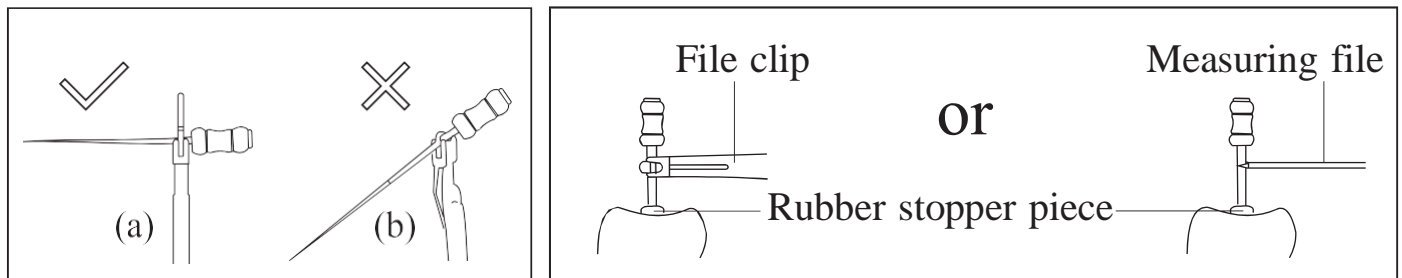

Fig. 4.8

4.4 Installation and operation of M2

- a) Align the cord plug with the connector at the left side of the device and insert the plug until it locks.
- b) Align the positioning pins of the contra-angle with the positioning slots of the motor handpiece and insert the head until it clicks. Insert the file into the chuck.
- c) Switch on and screen starts to display
- d) Select speed of rotation, torque and motor working model. You can also press the program key directly to switch out the previously stored settings

- e) Press the key on handpiece to start working.
- f) Torque value will be displayed on screen when working. (Fig. 4.9)
- g) Press switch button to switch direction of rotation.

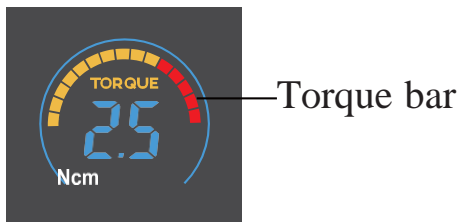

Fig. 4.9

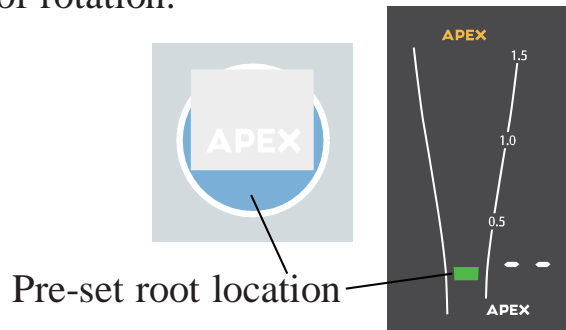

Fig. 4.10

4.5 Installation and operation of M3

- a) Same way to install and switch on handpiece as mode M2.
- b) In M3 mode, file starts reciprocating rotation with positive turn 170°, reverse 50°. The speed is about 300rpm.

4.6 Installation and operation of M4

- a) Same way to install and switch on handpiece as model M2.
- b) Same settings of rotation speed and torque as model M2.
- c) Press APEX key to set the apex location. (Fig. 4.10)
- d) Wear the silicon rubber case, and insert the single-head measuring wire into handpiece, then insert the lip hook into the socket of the single-head measuring wire to hang the lip hook on the mouth of patient.
- e) When the file into the root canal, it starts positive rotation. Slows down rotation speed when it comes to root top. Starts to reverse rotation when it comes to apical point which was set. Back to original rotation speed when away the root top. Stops when away root canal.
- f) It will automatically reversely rotate once real torque was over setting number. Unload and it will get back to positive rotation.

4.7 Installation and operation of M5

- a) Same way to install on handpiece as mode M3.
- b) Same settings of rotation speed and torque as mode M3.
- c) Press APEX key to set the apex location. (Fig. 4.10)
- d) Wear the silicon rubber case, and insert the single-head measuring wire into handpiece, then insert the lip hook into the socket of the single-head measuring wire to hang the lip hook on the mouth of patient.
- e) There is no need to press the STAR/STOP key on handpiece. When the file enters root canal, it starts reciprocating rotation with positive turn 170° & reverse 50°, and starts to reverse rotation when it comes to apical point which was set. Back to original reciprocating rotation when away the root top. Stops out of root canal.

Attention:

Due to root canal infection and other reasons, the root canal may be in a dry state, and the automatic rotation function will not work. In this case please inject liquid into root canal, such as hydrogen peroxide or saline. (Attention: no liquid overflow from the root canal.)

Excessive force can cause the file stuck in the root canal side wall.

A malfunction of the machine will cause rotation problem. In this case please watch on screen and operate it according to the touch feeling.

As the metal aging, file can be broken. Please timely replace it according to the requirements of the manufacturer.

When the file contacts with the patient's oral mucosa or teeth, the motor will automatically rotates which can harm the patient.

Pressing the front button of handpiece during the treatment will cause file fall off which can harm the patient.

5 Trouble Shooting

NO.	Problems	Possible caues	Solutions
1	No displays on the screen after turning on	1 The incorrect battery installation. 2 The lower power.	1 Install the battery correctly. 2. Recharge the battery.
2	File is not working	1.Handpiece and main unit are not connected. 2.Resistance is too large.	1. Check the connection. 2.Set a higher torque.
3	Endo file stops	1. Resistance is too large 2.Root canal in a bad situation	1.Set a higher torque 2.Change to non-root-canal measuring mode.
4	Root canal measurement values are inaccurate	1. Root canal in a bad situation 2. Electromagnetic interference	1. Removal of liquid and residual pulp 2. Please check the equipment used nearby, and be away from interference sources.
5	Endo file does not reverse rotate	1. The mode with automatic positive / reverse rotation function is not selected. 2.A too large torque value was set 3.Endo file does not reach the root top region.	1.Select automatic positive/reverse rotation model 2.Set a lower torque value 3.Endo file will automatically rotate when reaching root top.

NO.	Problems	Possible caues	Solutions
6	Endo file doesn't work in mode M4/M5	<ol style="list-style-type: none"> 1. Endo file does not enter the root canal 2. Root canal is too dry 3. A poor connection of file clip or measuring wire 4. Oral mucosa is too dry 5. Handpiece inserts into double-head measuring wire 	<ol style="list-style-type: none"> 1. Endo file need to enter root canal 2. Drip into proper saline 3. Remove contamination or replace spare part 4. Wet oral mucosa 5. Replace to a single-head measuring wire
7	File reversed too frequently	<ol style="list-style-type: none"> 1. Resistance is too large 2. Root canal in a bad situation 3. Root top setting point is too high 4. Root canal is narrow 5. Endo file is oversized 6. Electromagnetic interference 	<ol style="list-style-type: none"> 1. Set a higher torque 2. Removal of liquid and residual pulp or Change to non-root-canal measuring model. 3. Reset root top region. 4. Root-canal enlarge 5. Replace a smaller size file 6. Please check the equipment used nearby, away from interference sources.
8	Auto start / stop function is defective	<ol style="list-style-type: none"> 1. Root canal is too dry 2. Electromagnetic interference 	<ol style="list-style-type: none"> 1. Drip proper saline 2. Please check the equipment used nearby, away from interference sources.

Notice: If the problem can't be solved yet, please contact the local distributors or us.

6 Cleaning and Sterilization

6.1 After use, all parts that have contacted with the patients should be wiped by sterilized towel. (no bacteria, no fungi and no aldehyde liquid)

6.2 Cleaning with chemical reagents may cause damage to the instrument.

6.3 Contra angle, lip hook, clip and probe must be autoclaved before use.

6.4 Main unit, handpiece and measuring wire can't be autoclaved with high temperature and pressure.

7 Storage, maintenance and transportation

7.1 Storage

7.1.1 Handle with care, far away from vibration source. Install or store in a cool, dry, well-ventilated area.

7.1.2 Do not store with toxic, corrosive, flammable, explosive items.

7.1.3 Store in environment of relative humidity no more than 85%, atmospheric pressure 70kPa ~ 106kPa, temperature -10°C~ +50°C.

7.2 Maintenance

7.2.1 The product does not contain any user-serviceable accessories. Instrument maintenance should only be carried out by the professional trained maintenance personnel.

7.2.2 If the battery is fully charged but does not allow the instrument to function for at least one day, the battery must be replaced as soon as possible. Please use the original accessories, so as not to cause damage to the instrument.

7.3 Transportation

Avoid excessive shock and vibration during transport, handle with care, keep away from dangerous goods and avoid sun and rain.

8 Environmental Protection

The product does not contain harmful ingredients. Please handle base on local disposal policy.

9 Warranty

R-Smart Plus is warranted for 24 months from the date of purchase. The accessories (cables, battery etc.) are warranted for 6 months from the date of purchase. Please contact your local distributor for maintenance.

The warranty is valid for normal usage conditions. Any modification or accidental damage will render the warranty void.

10 Standard symbols



Power on/off



Sound adjustment

Registered trademark



Used indoor only



Date of manufacture



Manufacturer



Serial number



Attention, consult
accompanying document



Class II equipment



Type B Applied part



Direct current

IPX0

Ordinary equipment



Recovery



Keep dry



Handle with care

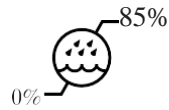

Storage relative humidity less than 85%RH

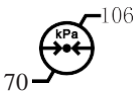

Storage atmospheric pressure at 70kPa~106kPa

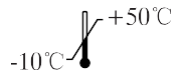

Storage temperature at -10°C~+50°C



Handle interface



Measuring wire interface



Deal with the product according to the WEEE (2002/96/EC)

11 Statement

All rights of modifying the product are reserved to the manufacturer without further notice. The pictures are only for reference.